

SwitchLine Non-fusible

Disconnect switches



SwitchLine

Non-fusible disconnect switches

16A – 3150A, 600V



ABB SwitchLine includes 16 different amperage sizes from 16A to 3150A. The basic construction provides flexibility, safety, and high performance in an extremely compact size. ABB SwitchLine is a perfect choice for all switching applications from industrial motor control to construction safety switches.

General information

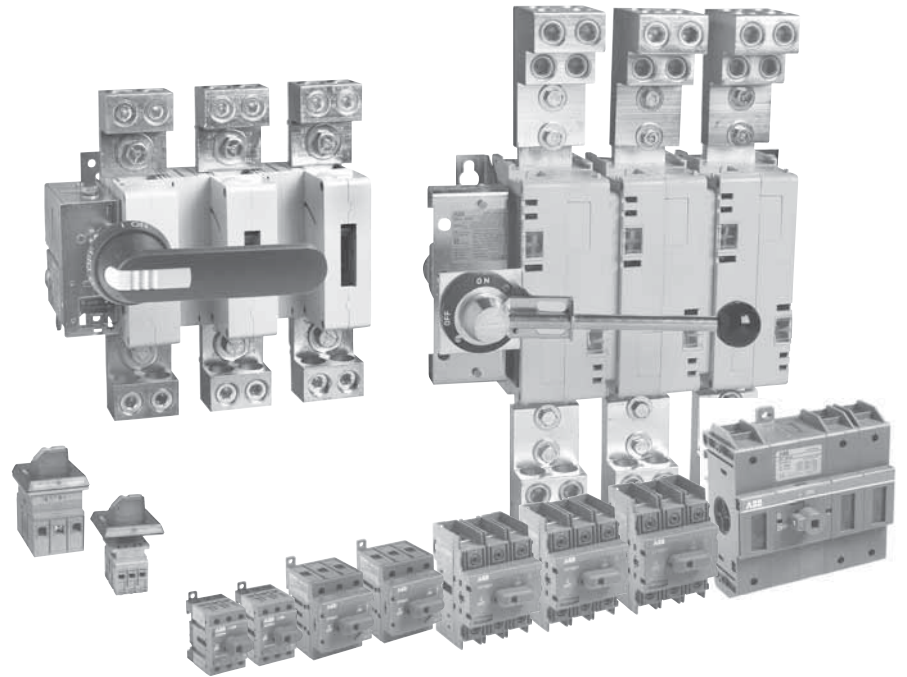

Versatility

ABB SwitchLine non-fusible disconnect switches are designed to offer maximum versatility in many ways.

Broad range

SwitchLine is seventeen amperage sizes from 16A – 3150A. All sizes are compact, heavy duty, 600V disconnect switches. Many sizes are available in 2, 3, 4, 6, and 8 pole configurations.

Compact size

The SwitchLine's compact dimensions allow panel size reduction in new applications or easily retrofit into space-sensitive existing installations.

International acceptance

UL listed, CSA approved, IEC rated, CE marked, and most other international standards.

UL98 (CSA 22.2 No.4) — UL File # E101914, CSA File #LR58077

For OT30, OT60, OT100, OT160, OT200, OT400, OETL-NF600 – OETL-NF2000 switches, OH_ pistol grip handles

Suitable for use as motor disconnects or industrial control panel disconnects on service entrance equipment, panelboards, switchboards, industrial control equipment, motor control centers, etc. and are horsepower rated and ampere rated.

UL508 (CSA 22.2 No. 14) — UL File # E63822, CSA File #LR58247

For OT16 – OT63 switches, OH_ selector handles

Suitable for use in equipment or machinery as motor controllers & motor disconnects and are horsepower and ampere rated.

IEC

Tested in accordance to IEC 947-1 and 3, IEC 664, IEC 269, and IEC 204

CE

Compliance with the European Machine Directive IEC 204 (EN 60204)

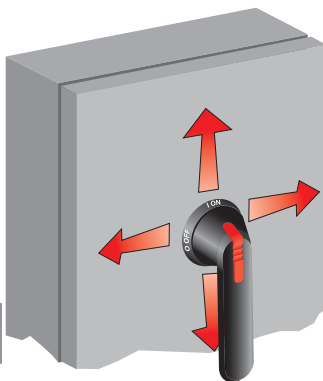

Installation options

Rotary through the door: available in all sizes, 16A – 3150A

Flange: versions available in 30A, 60A, 100A, & 200A sizes

A rotary disconnect switch may be installed nearly anywhere in a control panel — mounting is not limited to the upper right hand corner of the panel.

Mount the switch where it conveniently fits in your panel and simply install the handle on the door, in line with the switch. The switch and handle are mechanically linked through an easily adjusted shaft. This allows fast and easy installation into panels of different depths and layouts.

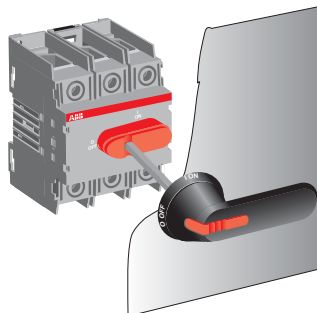

Rotary through the door installation

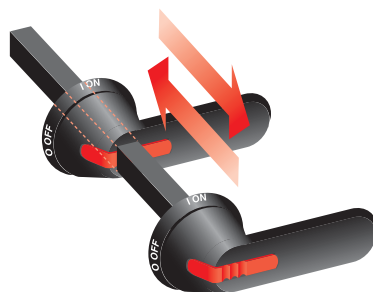

Easily adjusted shaft

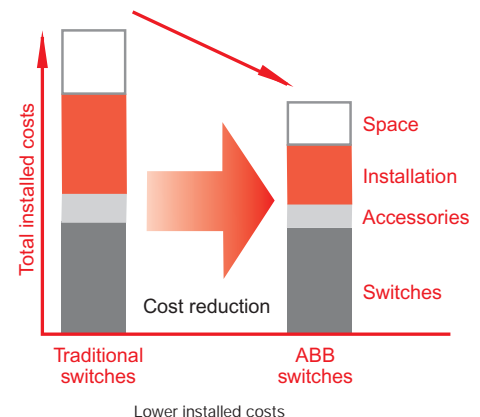

Broad range of accessories

- Handles — UL/NEMA type 1, 3R, 4, 4X, 12; IP54, 65, 66
- Auxiliary contacts available for every switch size
- Additional power poles
- Additional terminal poles (neutrals & grounds)
- Terminal shrouds
- 6 & 8 pole mechanisms
- Transfer mechanisms
- Bypass mechanisms
- Mechanical interlock mechanisms
- Electro-mechanical interlock mechanisms
- Motor operators

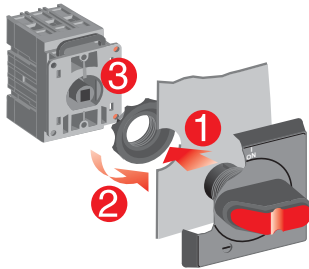
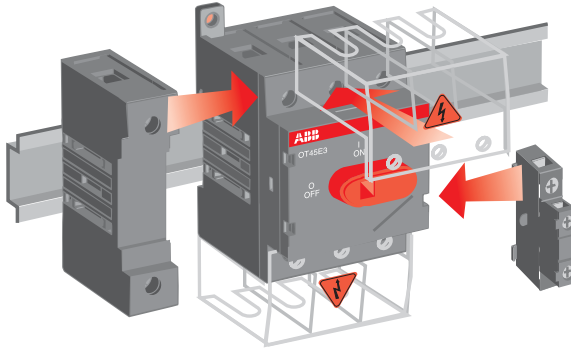

Door mounting

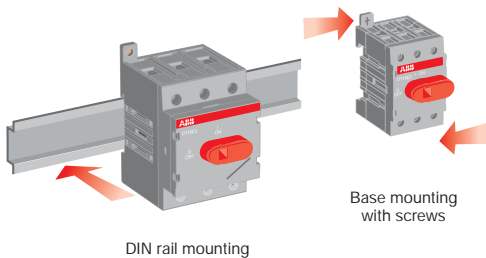

DIN rail mounting

Base mounting
with screws

Mounting

SwitchLine disconnect switches offer several mounting possibilities:

- Door mounting on an enclosure door or sidewall, 16A – 125A
- DIN rail mounting, 16A – 125A
- Base mounting with screws, 16A – 3150A

Mounting positions

SwitchLine disconnect switches may be mounted in any position:

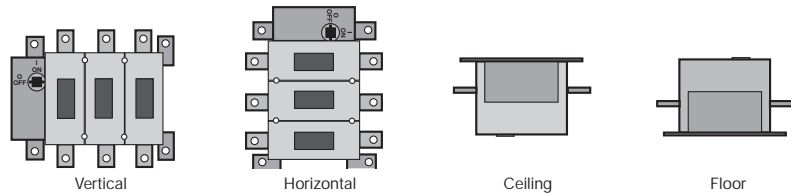

Incoming power feeds

SwitchLine disconnect switches can be used equally well with either top or bottom incoming power feeds.

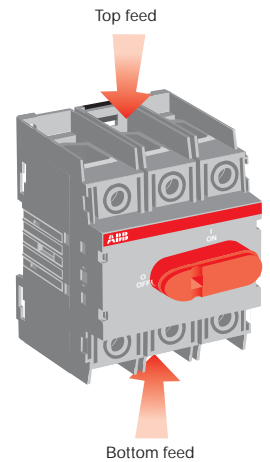

Terminal connections

Versatile connecting possibilities, 200A – 3150A:

- Ring tongue crimp on lugs
- Direct bus
- Terminal lugs

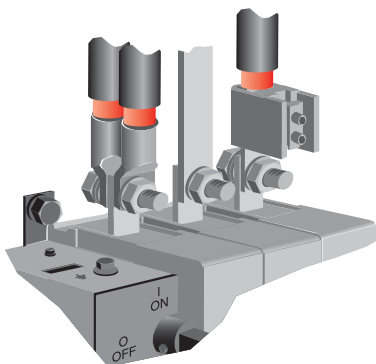

General information

Modular construction ①

Modular switch construction allows the operating mechanism to be placed at either end of the switch or anywhere in-between, 125A – 3150A.

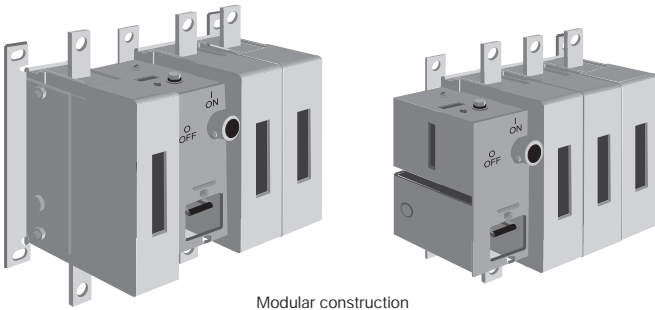

Modular construction

Finger proof

Dead-front construction plus terminal shrouds reduce the risk of touching live parts, improving the safety and reliability of the installation.

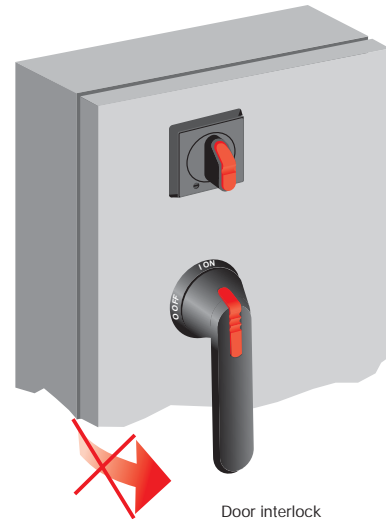

Door interlock

Door interlock

The handle and shaft provide a door interlock; the door can not be opened when the switch is in the "ON" position. NOTE: Some handles provide a method for qualified personnel to circumvent the door interlock. This is commonly referred to as a "defeater" mechanism.

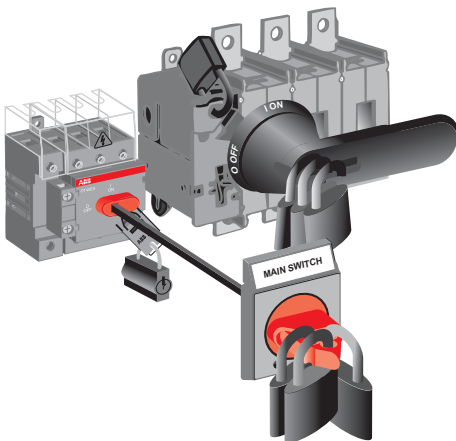

Handle and mechanism padlocked OFF

Padlockable

Handles can be padlocked in the "OFF" position with up to three padlocks: Additionally, the switch mechanism can be directly padlocked in the "OFF" position when the door is open. NOTE: Some handles can be ordered with the ability to padlock in both the "ON" & "OFF" positions, please consult your ABB sales office.

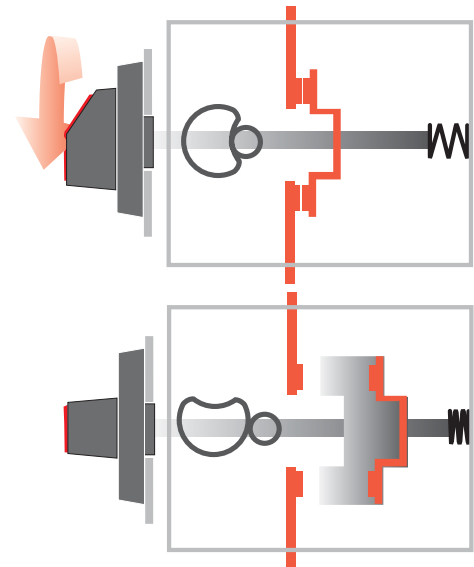

Positive opening operation

Positive opening operation

All switches operate according to the "positive opening operation" principle. This means the contacts are opened and closed by a driven mechanism, a solid moving bridge, not merely springs. This provides reliable position indication to the user; if the switch is in the "OFF" position, the contacts are open.

① Please consult ABB sales office for additional information.

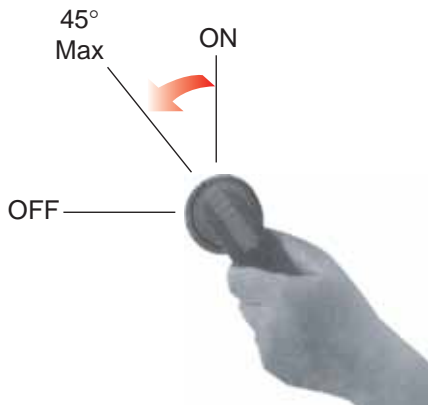

Welded contact protection

Positive opening operation safeguards users in case of welded contacts due to an overload or short circuit.

The switch can not reach the "OFF" position unless the contacts are truly open. If any or all of the contacts are welded shut, the switch mechanism will only allow the handle to operate a maximum of 45°. This safeguards personnel by:

- alerting them a problem has occurred
- maintaining the door interlock and
- not allowing a padlock to be inserted.

Clear position indication

All switches and handles have clear "ON" and "OFF" designations. Whether the door is open or closed, it is possible to simply look at the switch and determine if the switch is "ON" or "OFF".

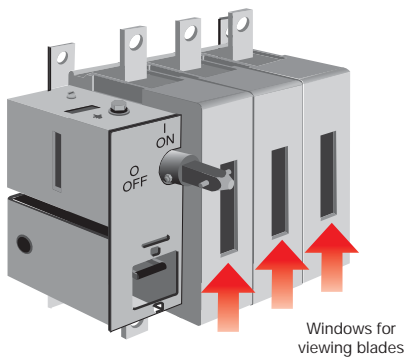

Visible blades

Visible blades offer additional safety from 125A — 1200A.

Track resistant material

Excellent track resistant material, CTI > 600V, IEC 112, reduces the risk of flashover between phases in even the most severe circumstances.

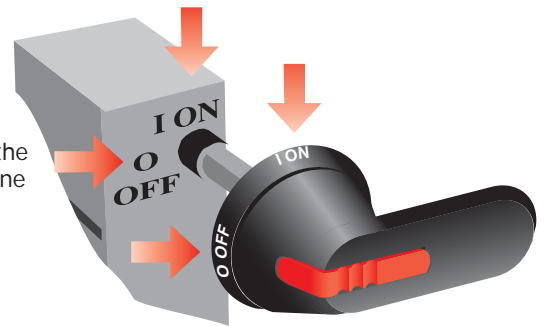

Constant control

The OT16E3 to OT100E3 provide the user with constant control over the power circuit. Whether the enclosure door is open or closed, qualified personnel have the ability to manually operate the switch. This is most meaningful when qualified personnel are working with the enclosure door open: In case of an emergency down-stream, the main three phase power can be disconnected immediately using the red, direct mounted handle.

